

DUMPS ARENA

Implementing Aruba Campus Switching solutions

HP HPE6-A45

Version Demo

Total Demo Questions: 10

Total Premium Questions: 172

Buy Premium PDF

<https://dumpsarena.com>

sales@dumpsarena.com

dumpsarena.com

QUESTION NO: 1

Refer to the exhibit.

```
Switch-1# show access-list resources
Resource usage in Policy Enforcement Engine

Ingress Policy Enforcement Engine Rules

Resource usage in Policy Enforcement Engine
```

Ports	Rules Available	Rules Used							
		ACL	QoS	IDM	VT	Mirr	PBR	OF	Other
1-28	320	3740	0	0	0	0	0	0	10

An AOS-Switch has an extended ACL that is applied to several physical interfaces.

- New interfaces have been brought online.
- The ACL has been applied to them as well.

A network administrator sees the output in the exhibit and is concerned that the switch will reach the limit for rules.

What can the administrator do to address this concern?

- A. Resequence the ACL with less space in between the entries.
- B. Enable ACL grouping, and apply ACLs as shared ACLs.
- C. Reconfigure the ACL as a standard ACL, and then reapply it.
- D. Remove static ACLs, and have the RADIUS server send dynamic ACLs.

ANSWER: A

QUESTION NO: 2

Refer to the exhibit.

```
radius-server key password
radius-server host 10.1.10.10 dyn-authorization
radius-server host 10.1.10.11 dyn-authorization
```

AOS-Switches will enforce 802.1X authentication on edge ports. The company has two RADIUS servers, which are meant to provide redundancy and load sharing of requests. The exhibit shows the planned RADIUS setting to deploy to the switches.

Which adjustment to the plan should administrators make in order to meet the customers' requirements?

- A. Remove the dynamic authorization setting for both RADIUS servers.
- B. Specify a different RADIUS dynamic authorization port for each of the RADIUS servers.
- C. Specify one server on half of the switches and the other server on the other half of the switches.
- D. Change the order in which the RADIUS servers are specified on half of the switches.

ANSWER: D

QUESTION NO: 3

Refer to the exhibit.

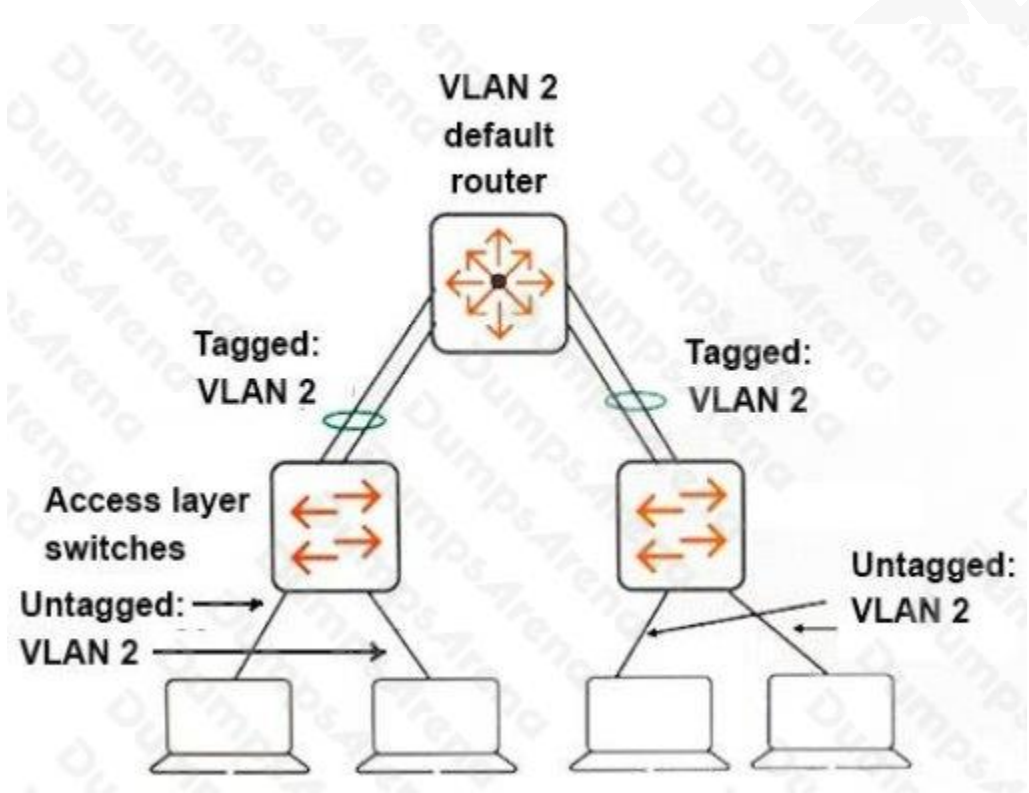

The access layer AOS-Switches currently run DHCP snooping on VLAN 2 and connection rate filtering on edge ports. They are at default settings for ARP protection. A network administrator then enters these commands on each of the access layer switches:

```
Switch(config)# arp-protect vlan 2 Switch(config)# arp-protect
```

Which behavior accurse?

- A. The switches will forward legitimate traffic and prevent ARP poisoning attacks, but interfere with connection rate filtering.
- B. The switches can now prevent ARP poisoning attacks and do not interfere with legitimate communications.
- C. The switches can prevent ARP poisoning attacks, but legitimate communications with VLAN 2 could also be disrupted.
- D. The switches will not apply ARP protection due to interference from DHCP snooping, so the commands have no effect on current behavior.

ANSWER: B

QUESTION NO: 4

Network administrators need to inspect all traffic that arrives on an AOS-Switch in VLAN 2 and is destined to TCP ports 50000-50010. They want to send the traffic to a protocol analyzer connected to the switch for deeper inspection.

What else must they create to achieve their goal?

- A. an extended IP ACL that selects the TCP traffic, apply the ACL to interfaces VLAN 2, and specify interfaces in VLAN 2 as monitor ports
- B. a traffic class that selects the TCP traffic, map the class to the mirror session in a policy to VLAN 2
- C. a traffic class that selects the TCP traffic, and apply the traffic class directly to the interface that connects to the protocol analyzer
- D. a traffic class that selects the TCP traffic, and apply the traffic class directly to the interface that connects to the protocol analyzer
- E. an extended IP ACL that selects the TCP traffic, apply the ACL to the mirror session, and specify interfaces in VLAN 2 as monitor ports

ANSWER: B

QUESTION NO: 5

Refer to the exhibit.

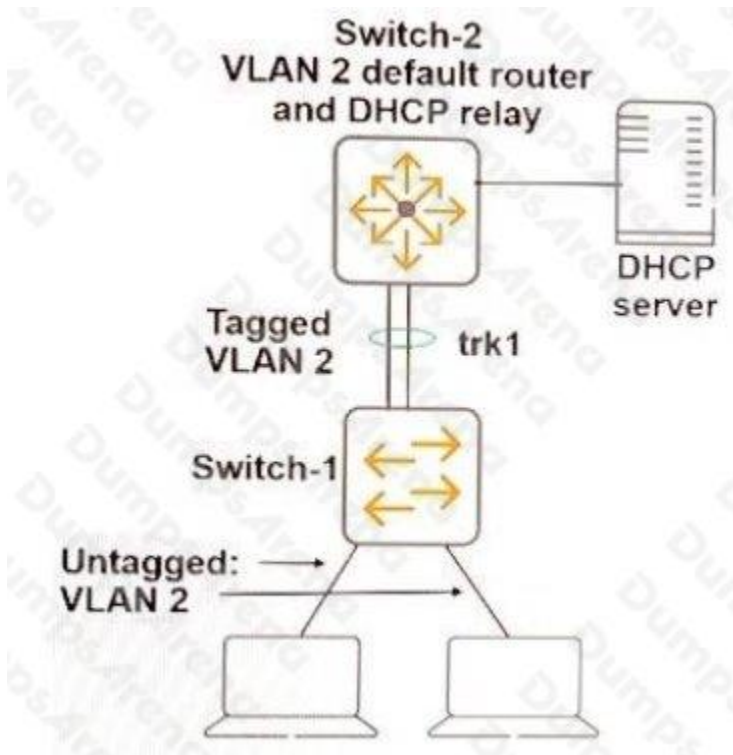

The network administrator enables DHCP snooping globally and on VLAN 2. An additional step is mandatory for DHCP snooping to operate correctly and for clients to receive DHCP settings.

What is the additional mandatory step?

- A. Define trk1 as a trusted DHCP port.
- B. Define an authorized DHCP server.
- C. Enable ARP protection.
- D. Define edge ports as untrusted DHCP ports.

ANSWER: D

QUESTION NO: 6

What is a typical reason to implement MAC authentication on an AOS-Switch?

- A. to filter traffic at the edge, based on multiple criteria in the MAC header
- B. to provision switch ports to support devices such as IP phones or printers
- C. to enhance the security of an 802.1X solution
- D. to control management access to the switch CLI based on device, as well as user credentials

ANSWER: C**QUESTION NO: 7**

Which switches can be deployed in a mesh topology for backplane stacking?

- A. Aruba 2920 switches
- B. Aruba 2930F switches
- C. Aruba 2930M switches
- D. Aruba 3810 switches

ANSWER: D**Explanation:**

Reference: <https://www.hpe.com/us/en/product-catalog/networking/networking-switches/pip.aruba-3810-switch-series.1008605435.html>

QUESTION NO: 8

Refer to the exhibit.

```
Switch# ping 10.1.10.5
10.1.10.5 is alive, time = 3 ms
```

```
Switch# show radius authentication
```

```
Status and Counters - RADIUS Authentication Information
```

```
NAS Identifier      : Access-1
```

```
Invalid Server Addresses : 0
```

Server IP Addr	UDP Port	Timeouts	Requests	Challenges	Accepts	Rejects
10.1.10.5	1812	6	3	0	0	0

A network administrator sets up 802.1X authentication to a RADIUS server on an AOS-Switch. The RADIUS server and user devices are both set up to use PEAP MSCHAPv2. The administrator tests the authentication and sees the output shown in the exhibit. Which issue could cause this output?

- A. The administrator entered the wrong password for the test account
- B. The RADIUS shared secret does not match on the switch and the server
- C. The switch does not have a certificate for port-access installed on the switch
- D. The switch port is set for user mode 802.1X, but the RADIUS server is set for port mode

ANSWER: B**QUESTION NO: 9**

Refer to the exhibit.

```
Switch-1# show link-keepalive
Status and Configuration - UniDirectional Link Detection (UDLD)

Keepalive Retries      : 4
Keepalive Interval    : 5000 ms
Keepalive Mode        : forward-then-verify

      Physical      Keepalive Adjacent      UDLD
Port  Enabled  Status      Status      Switch      VLAN
-----
A23  Yes      up          failure     00fd45-653ae9  untagged
```

Switch-1 and Switch-2 connect on interface A23. The switches experience a connectivity issue. The network administrator sees that both switches show this interface as up. The administrator sees the output shown in the exhibit on Switch-1.

What is a typical issue that could cause this output?

- A. a hardware issue, such as a broken cable
- B. asymmetric routing introduced by a routing configuration error
- C. an issue with queuing, caused by mismatched QoS settings
- D. mismatched IP addresses on the VLAN for the link

ANSWER: A**QUESTION NO: 10**

A company has AOS-Switches, Aruba ClearPass, and Aruba AirWave. A network administrator needs to set up a new switch with the same settings found on other switches in the company.

Which action is likely to be the most useful to perform the task?

- A. View usage patterns on the switches on AirWave.
- B. Retrieve the running config from ClearPass.
- C. Use the configuration audit tool on AirWave.

D. Access the Network Device view on ClearPass.

ANSWER: B

DUMPSARENA